

General Description

Poppet Type, Bi-Directional, Normally Closed, Pilot to Close Logic Element. For additional information see Technical Tips on pages LE2-LE7.

Features

- Hardened, precision ground parts for durability
- Polyurethane seals only
- No backup rings
- Low leakage design
- All external parts zinc plated
- Port 2 to 1 is the preferred flow path

Performance Curve

Pressure Drop vs. Flow (Through cartridge only)

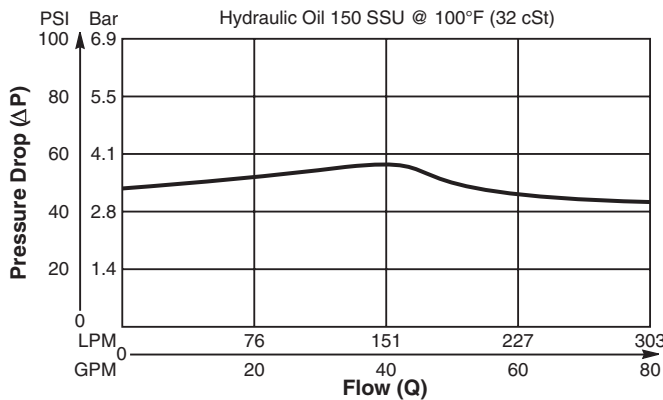

Specifications

Rated Flow	303 LPM (80 GPM)
Maximum Inlet Pressure	240 Bar (3500 PSI)
Leakage at 150 SSU (32 cSt)	5 drops/min. (.33 cc/min.) @ 240 Bar (3500 PSI)
Cartridge Material	All parts steel. All operating parts hardened steel.
Operating Temp. Range/Seals	-37°C to +107°C (Polyurethane, EPS) (-35°F to +225°F) -26°C to +204°C (Fluorocarbon) (-15°F to +400°F)
Fluid Compatibility/Viscosity	Mineral-based or synthetic with lubricating properties at viscosities of 45 to 2000 SSU (6 to 420 cSt)
Filtration	ISO-4406 18/16/13, SAE Class 4
Approx. Weight	0.81 kg (1.78 lbs.)
Cavity	C20-3S (See BC Section for more details)

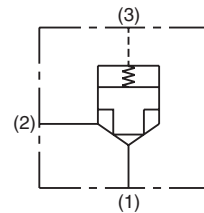
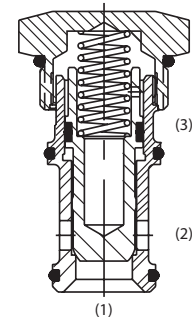

Dimensions Millimeters (Inches)

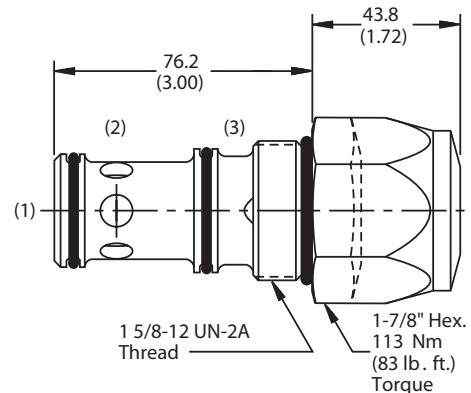

Ordering Information



Highlighted represents preferred options that offer the shortest lead times. Other options may be available, but at extended lead times.

Code	Bias Spring
100	6.9 Bar (100 PSI)
150	10.3 Bar (150 PSI)

Code	Seals
Omit	Polyurethane, EPS

Kit	Part Number
Polyurethane, EPS Seal	WRK-20-3S
Fluorocarbon Seal	WRK-20-3S-W

CV
Check Valves
SH
Shuttle Valves
LM
Load/Motor Controls
FC
Flow Controls
PC
Pressure Controls
LE
Logic Elements
DC
Directional Controls
SV
Solenoid Valves
PV
Proportional Valves
CE
Coils & Electronics
BC
Bodies & Cavities
TD
Technical Data